

DEPARTMENT OF LICENSING AND REGULATORY AFFAIRS

DIRECTOR'S OFFICE

CONSTRUCTION SAFETY STANDARDS

(By authority conferred on the director of the department of licensing and regulatory affairs by sections 19 and 21 of 1974 PA 154, MCL 408.1019 and 408.1021 and Executive Reorganization Order Nos. 1996-2, 2003-1, 2008-4, and 2011-4, MCL 445.2001, 445.2011, 445.2025, and 445.2030)

PART 19. TOOLS

R 408.41901 Scope.

Rule 1901. This standard pertains to the manufacture, care, and use of tools for construction operations.

History: 1979 AC; 2016 MR 19, Eff. Oct. 13, 2016.

R 408.41902 Adopted and referenced standards.

Rule 1902. (1) The following standards are adopted by reference in these rules and are available from IHS Global, 15 Inverness Way East, Englewood, Colorado, 80112, USA, telephone number: 1-800-854-7179 or at website: www.global.ihs.com, at a cost as of the time of adoption of these rules, as stated in this rule:

(a) American National Standards Institute (ANSI) 01.1 "Safety Code for Woodworking Machinery," 1961 edition. Cost: \$20.00.

(b) ANSI A10.3 "Powder-Actuated Fastening Systems," 1985 edition. Cost: \$20.00.

(c) American Society of Mechanical Engineers (ASME) Boiler and Pressure Vessel Code, Section VIII, "Unfired Pressure Vessels," 1980 edition. Cost: \$514.00.

(2) The standards adopted in these rules are available for inspection at the Department of Licensing and Regulatory Affairs, MIOSHA Regulatory Services Section, 530 West Allegan Street, P.O. Box 30643, Lansing, Michigan, 48909-8143.

(3) Copies of the standards adopted in these rules may be obtained from the publisher or may be obtained from the Department of Licensing and Regulatory Affairs, MIOSHA Regulatory Services Section, 530 West Allegan Street, P.O. Box 30643, Lansing, Michigan, 48909-8143, at the cost charged in this rule, plus \$20.00 for shipping and handling.

(4) The following Michigan occupational safety and health (MIOSHA) standards are referenced in these rules. Up to 5 copies of these standards may be obtained at no charge from the Michigan Department of Licensing and Regulatory Affairs, MIOSHA Regulatory Services Section, 530 West Allegan Street, P.O. Box 30643, Lansing, Michigan, 48909-8143 or via the internet at website:

www.michigan.gov/mioshastandards. For quantities greater than 5, the cost, at the time of adoption of these rules, is 4 cents per page.

(a) Construction Safety Standard Part 6 “Personal Protective Equipment,” R 408.40601 to R 408.40641.

(b) Construction Safety Standard Part 17 “Electrical Installations,” R 408.41701 to R 408.41734.

(c) Construction Safety Standard Part 22 “Signals, Signs, Tags and Barricades,” R 480.42201 to R 408.42242.

(d) Occupational Health Standard Part 621 “Health Hazard Control for Specific Equipment and Operations for Construction,” R 325.62102 to R 325.62126.

History: 2013 AACCS; 2016 MR 19, Eff. Oct. 13, 2016.

R 408.41926 Definitions; A to D.

Rule 1926. (1) "Abrasive wheel" means a cutting tool that consists of abrasive grains held together by a bonding material.

(2) "Alligator shear" means a machine which has a powered blade and a fixed blade and which creates a shearing action when the moving blade meets the fixed blade.

(3) "Approved tool" means a tool that meets the requirements for specific operations as prescribed in this part.

(4) "Band saw" means a machine equipped with 2 wheels on which a continuous band blade rides.

(5) "Chamber" means to fit without the use of force.

(6) "Circular table saw" means a machine which has a circular blade and a table to support the material and which is used for ripping, crosscutting, dadoing, and rabbeting.

(7) "Combination or universal machine" means a machine which combines several operations, such as sawing, jointing, and drilling.

(8) "Cutter head" means a powered holder for a cutting blade.

History: 1979 AC; 1989 AACCS.

R 408.41927 Definitions; G to O.

Rule 1927. (1) "Grounded" means grounding as required by Construction Safety Standard Part 17 “Electrical Installations,” as referenced in R 408.41902.

(2) "Guard" means an enclosure designed to restrain pieces of abrasive wheel and protect the employee in the event of wheel breakage.

(3) "Hammer-actuated piston tool" means a low-velocity, powder-actuated device that, when struck by a heavy hammer and supplemented by a power load, moves a captive piston to drive a fastener into a material.

(4) "Hand tool" means an instrument used or worked by hand.

(5) "Hand-held circular saw" means a hand-held machine that has a circular blade and that is used for crosscutting and ripping.

(6) "Hand-held powered tool" means a tool that is operated by hand, but powered by other means.

(7) "Jack" means a device for lifting and lowering a load or moving it horizontally by application of a pushing force.

(8) "Jointer" means a machine with a revolving cutter head set into an adjustable table over which the material is moved across the cutter head.

(9) "Lockout" means to secure by use of a lock.

(10) "Masonry cutting" means the cutting off, notching, or slotting of units of materials such as brick, tile, block, or refractory shapes where the workpiece is brought into the machine.

(11) "Minimum clear hot stick distance" means the distance from an energized conductor or equipment to the closest hand of the employee holding the hot stick.

(12) "Offhand grinding" means the grinding of any material that is held in an employee's hand.

History: 1979 AC; 1989 AACS; 2016 MR 19, Eff. Oct. 13, 2016.

R 408.41928 Definitions; P.

Rule 1928. (1) "Point of operation" means that point at which cutting, shaping, working, assembling, or forming is accomplished upon the stock.

(2) "Point of operation device" means a control or attachment which does any of the following:

(a) Restrains the operator from inadvertently reaching into the point of operation.

(b) Prevents normal machine operation if the operator's hands are inadvertently within the point of operation.

(c) Automatically withdraws the operator's hands if they are within the point of operation as the machine cycles.

(3) "Portable powered stapler and nailer" means a tool that drives a staple or nail by mechanical, pneumatic, or electrical power into a workpiece, but does not mean a general office stapler.

(4) "Portable powered tool" means a machine or instrument which is carried or moved by hand and which is powered by something other than the hand.

(5) "Powder-actuated tool" means a device that makes instantaneous forced-entry fastenings into construction materials through the use of a fastener and an explosive load.

(6) "Powered bender" means a machine that consists of dies or fixtures located between a moving and a fixed machine part. When metal is placed between the parts, the moving part is pressed against the fixed part, bending the metal to the desired shape.

(7) "Powered feed rolls" means parallel rolls that run inward to move material into the point of operation of a machine.

(8) "Power load" means a substance that is capable of producing a propellant force in a powder-actuated tool.

(9) "Protective shield" means a device or guard which is attached to the muzzle end of a powder-actuated tool to confine flying particles.

(10) "Push block" means a short block of wood which has a handle similar to that of a plane, a shoulder at the rear end, and is used for pushing stock over revolving cutters.

(11) "Push stick" means a narrow strip of wood or other soft material which has a notch or sharp point on 1 end and which is used to push material through the point of operation of a cutting tool.

History: 1979 AC; 1989 AACS.

R 408.41929 Definitions; Q to W.

Rule 1929. (1) "Qualified operator" means an employee who possesses a valid operator's card issued pursuant to R 408.41942 for the operation of powder-actuated tools.

(2) "Radial saw" means a machine with a circular blade suspended from a horizontal arm.

(3) "Rating" means the maximum working load that an object is designed to handle under given circumstances.

(4) "Roll form machine" means a machine that has in-running rolls which are arranged to form a desired shape of metal when the metal is fed through the rolls.

(5) "Slitter" means a machine that has circular knives mounted on powered shafts with the cutting faces adjacent to each other in a manner that shears metal when it is fed through the knives.

(6) "Squaring shear" means a machine which has a table and which utilizes a driven ram with a blade for shearing action. The ram moves a nonrotary blade, at a constant rate, past the edge of a fixed blade at the table and cuts metal.

(7) "Stationary machine tool" means a machine that is set up on a construction project in a temporary, stationary position.

(8) "Tool" means a machine, instrument, or device covered by this part.

(9) "Tuck-point grinding" means the removal of mortar or cement between masonry units by grinding.

(10) "Woodworking machine" means a machine which removes, shapes, or cuts wood or is used to assemble parts.

History: 1979 AC; 1989 AACS.

R 408.41931 Rescinded.

History: 1979 AC; 2013 AACS.

R 408.41932. Tools generally.

Rule 1932. (1) Regardless of ownership, a tool or part of a tool with a defect that could cause an injury shall be replaced or repaired before use.

(2) When a guard is provided on a tool, the guard shall not be made inoperative. The guard may be removed only for repair, service, or setup, and it shall be replaced before the tool is returned to use.

(3) Hand tools or portable powered tools shall not be left on a scaffold, ladder, or work platform after the completion of the work operation or day. Before the scaffold, ladder, or work platform is moved, all tools shall be removed or properly secured against displacement.

(4) A tool shall be visually inspected by the user for safe operation before each daily use and, when found defective, shall be removed from service and tagged. The tag shall be in compliance with Construction Safety Standard Part 22 "Signals, Signs, Tags, and Barricades," as referenced in R 408.41902.

(5) A tool that is used in a potentially explosive atmosphere shall be designed and approved for such atmosphere.

(6) A safety device or operating control shall not be made inoperative, except for the removal of lock-on control devices.

History: 1979 AC; 1989 AACCS; 2013 AACCS; 2016 MR 19, Eff. Oct. 13, 2016.

R 408.41933 Portable powered tools; controls.

Rule 1933. (1) A hand-held powered circular saw which has a blade diameter of more than 2 inches; an electric, hydraulic, or pneumatic chain saw; and a percussion tool without positive accessory holding means shall be equipped with a constant-pressure switch or control that shuts off the power when the pressure is released. A gasoline-powered, hand-operated tool shall be equipped with a constant-pressure throttle control. A throttle position lock may be provided for starting only.

(2) All of the following tools shall be equipped with a constant-pressure switch or control and may have a lock-on control if the tool can be turned off by a single motion of the same finger or fingers that turn it on without release of the grip on the tool:

- (a) A hand-held powered drill.
- (b) Tapper.
- (c) Fastener driver.
- (d) Grinder with a wheel more than 2 inches in diameter.
- (e) Disc sander with a disc more than 2 inches in diameter.
- (f) Belt sander.
- (g) Reciprocating saw.
- (h) Saber saw.
- (i) Scroll saw.
- (j) Jigsaw with a blade shank more than a nominal 1/4 inch.
- (k) Similarly operating power tool.

The lock-on control of a drill of more than 3/8-inch capacity shall not be used when the drill is held in the hand to drill, clean, or enlarge a hole.

(3) All of the following hand-held powered tools may be equipped with either a positive on-off control or other control as prescribed in subrules (1) and (2) of this rule:

- (a) A platen sander.
- (b) Grinder with a wheel 2 inches or less in diameter.
- (c) Disc sander with discs 2 inches or less in diameter.
- (d) Router.

- (e) Planer.
- (f) Laminate trimmer.
- (g) Nibbler.
- (h) Shear.
- (i) Saber saw.
- (j) Scroll saw.
- (k) Jigsaw with a blade shank of nominal 1/4 inch or less.

(4) The operating control on a hand-held power tool shall be located so as to prevent accidental operation.

History: 1979 AC; 1989 AACS.

R 408.41934. Electric-powered tools.

Rule 1934. (1) An electric-powered tool, such as a saw, drill motor, and router, shall be grounded. This requirement does not pertain to ungrounded electrical systems. Ground fault circuit interrupters shall be used with ungrounded electrical systems.

(2) Subrule (1) of this rule does not apply to a double insulated electric power tool labeled with underwriters laboratory or other nationally recognized testing laboratory approval for double-insulated tools.

(3) A portable, power-driven circular saw shall be equipped with a guard above and below the base plate or shoe. The upper guard shall cover the saw to the depth of the teeth, except for the minimum arc required to allow proper retraction and contact with the work. When the saw is withdrawn from the work, the lower guard shall return automatically and instantly to the covered position.

(4) The trailing cord of a portable powered tool shall not be used to hoist or lower the tool.

(5) A powered tool shall be disconnected from its power source when it is serviced or when the point of operation device is changed by a device or tool.

(6) When not grounded or double-insulated, an electrically powered hand tool used for the installation of power transmission and distribution systems shall be connected to the power supply by means of an isolating transformer or other isolated power supply.

History: 1979 AC; 1989 AACS; 2013 AACS.

R 408.41935. Portable pneumatic-powered tools.

Rule 1935. (1) Safety clips or retainers shall be installed on pneumatic impact tools to prevent dies and tools from being accidentally expelled from the barrel.

(2) Pressure shall be shut off by means of a valve and exhausted from lines before disconnecting the lines from tools or connections, except when using a quick makeup coupling.

(3) Safety fasteners shall be provided at connections between tools and hose lines and at all quick makeup-type connections to prevent accidental disengagement.

(4) The rated pressure capacity of hoses, pipes, filters, valves, and fittings shall be not less than the rated pressure capacity of the tool. The pneumatic tool and its accessories shall not be operated at a pressure that is more than the rated capacity.

(5) Defective hoses or connections shall be removed from service.

(6) A hose shall not be used for hoisting or lowering a pneumatic-powered tool.

(7) A pneumatic-powered tool that has a hose which has an inside diameter of more than 1/2 of an inch shall have a safety device at the source of supply or branch line to reduce the pressure in case of hose failure.

(8) An airless spray gun that atomizes paint and fluids at a pressure of more than 1,000 pounds per square inch shall be equipped with an automatic or visible manual safety device that prevents the pulling of the trigger to release the paint or fluid until the safety device is manually released.

(9) Abrasive blast cleaning nozzles shall be equipped with an operating valve that can only be held open manually. A support shall be provided on which the nozzle may be mounted when it is not in use.

History: 1979 AC; 1989 AACS; 1995 AACS; 2013 AACS.

R 408.41936 Cleaning with compressed air.

Rule 1936. (1) Compressed air shall not be used for blowing dirt or dust from the hands, face, or clothing.

(2) Air pressure at the discharge end of a portable air gun or hose used for cleaning shall not exceed 30 pounds per square inch gauge (p.s.i.g.), except the pressure may exceed 30 p.s.i.g. when sandblasting, cleaning concrete forms, or for joint cleaning. When air pressure exceeding 30 p.s.i.g. is used for concrete forms or joint cleaning, a pipe extension of not less than 4 feet shall be used at the end of the hose.

(3) When air under pressure is used to remove chips or dust, a chip guard, such as a fixed or removable shield, safely located, shall be provided to protect the operator and any employee in an adjoining area.

(4) The employee using air under pressure shall use personal protective equipment provided for and as prescribed in Construction Safety Standard Part 6 "Personal Protective Equipment," as referenced in R 408.41902, to protect against hazards created by the operation.

History: 1979 AC; 1982 AACS; 2016 MR 19, Eff. Oct. 13, 2016.

R 408.41937 Powered staplers and nailers.

Rule 1937. (1) A portable powered stapler or nailer that is capable of driving a fastener that has a diameter of more than .0475 inch, 18 gauge A.W.G., at more than 75 feet per second shall be designed so that the operator is required to make not less than 2 separate operations to activate the tool, with 1 operation being to place the tool against the work surface.

(2) The design shall prevent the discharge of the stapler or nailer when loading or when dropped.

(3) A portable powered stapler or nailer shall not be pointed or discharged at other than the workpiece.

(4) The operator of a portable powered stapler or nailer and those employees within the striking distance of its fastener shall wear eye protection provided for and as

prescribed in Construction Safety Standard Part 6 “Personal Protective Equipment,” as referenced in R 408.41902.

(5) A positive actuation of the operator control shall be required to propel each fastener from a powered stapler or nailer.

(6) When relieving a jam-up of a fastening device, the source of power shall be disconnected.

(7) Before use, a portable powered stapler and nailer shall be tested for safe operation.

History: 1979 AC; 1982 AACCS; 1989 AACCS; 2016 MR 19, Eff. Oct. 13, 2016.

R 408.41938 Hand tools.

Rule 1938. (1) A pipe, socket, end, or adjustable wrench or pliers having sprung or worn jaws that allow slippage shall not be used.

(2) Impact tools such as, but not limited to, a drift pin, chisel, wedge, or hammer, shall be kept free of mushroomed heads.

(3) A wooden handle of a hand tool that is split, cracked, or splintered shall not be used.

(4) A measuring tape or device that is metal or contains conductive strands shall not be used when working on or near electrically energized parts.

History: 1979 AC.

R 408.41941 Powder-actuated tool operators' qualifications.

Rule 1941. An operator of a powder-actuated tool shall be trained to clean the tool correctly and to recognize any worn or defective part or defective operation. The operator shall be able to use the powder-actuated tool safely under varying conditions, know the limitations of its use, and demonstrate competence by actually operating the tool in the presence of the persons who issue the operator's card. The operator shall be familiar with the provisions of these rules and the instructions provided by the manufacturer for operation and care of the powder-actuated tool to be operated, and be able to read the instructions.

History: 1979 AC.

R 408.41942 Powder-actuated tool operators' cards.

Rule 1942. (1) An operator of a powder-actuated tool shall have an operator's card that should be in the operator's possession at all times while using the tool and be presented upon request or an employer may establish and maintain at the jobsite a list of employees qualified to operate a powder-actuated tool.

(2) Failure to comply with any of these rules is sufficient cause for the immediate surrender of an operator's card to the employer.

(3) The purpose of the card is to certify that the operator has completed the required training to become a qualified operator.

(4) The card should be of a size, approximately 2 1/2 by 3 1/2 inches, that readily fits into a wallet.

(5) The face of the card should include the following text and bear the signature of the issuer of the card, authorized as provided in subrule (8) of this rule:

QUALIFIED OPERATOR POWDER-ACTUATED FASTENING TOOLS
DATE:
SERIAL NUMBER:
NAME OF OPERATOR:
THIS CERTIFIES THAT THE ABOVE NAMED OPERATOR HAS RECEIVED THE PRESCRIBED TRAINING IN THE OPERATION OF POWDER-ACTUATED FASTENING TOOLS MANUFACTURED BY THE FOLLOWING:
NAME OF MANUFACTURER:
MODEL(S):
AUTHORIZED ISSUER:
SIGNATURE OF OPERATOR:

(6) A statement should be provided on the card as follows:

"I have received instruction in the safe operation of powder-actuated fastening tools of the makes and models specified, and I agree to conform to the rules governing their use."

(7) A note should be printed on the card as follows:

"Revocation of Card Failure to comply with any rule for safe operation of powder-actuated fastening tools is sufficient cause for the immediate surrender of the card to the employer."
--

(8) The manufacturer of a powder-actuated tool should establish an appropriate program to instruct its employees, dealers, and distributors in the proper technical training and testing of operators and the issuance of operators' cards. Operators' cards may be issued by either of the following:

(a) A dealer or distributor of powder-actuated tools, who has been authorized by the tool manufacturer to issue such cards.

(b) An authorized employee of a powder-actuated tool manufacturer.

History: 1979 AC; 2016 MR 19, Eff. Oct. 13, 2016.

R 408.41943. Powder-actuated tool operation.

Rule 1943. (1) An operator and assistant using a powder-actuated tool shall be safeguarded by means of eye protection. Head and face protection shall be used as required by the working conditions. Eye protection and head and face protection shall be provided for and as prescribed in Construction Safety Standard Part 6 “Personal Protective Equipment,” as referenced in R 408.41902.

(2) Before using a powder-actuated tool, the operator shall inspect it to determine to the operator’s satisfaction that it is clean, that all moving parts operate freely, and that the barrel is free from obstructions. A tool found not to be in proper working order, or that develops a defect during use, shall be immediately removed from service and tagged, and not used until repaired. The tag shall be as prescribed in Construction Safety Standard Part 22 “Signals, Signs, Tags, and Barricades,” as referenced in R 408.41902.

(3) A powder-actuated tool shall not be loaded until just prior to the intended firing time. An unattended powder-actuated tool shall not be left loaded.

(4) A powder-actuated tool shall not be left unattended in a place where it is available to unauthorized persons.

(5) Neither a loaded nor an empty powder-actuated tool shall be pointed at any employee, and hands should be kept clear of the open barrel end.

(6) A fastener shall not be driven under any of the following conditions:

(a) Through an existing hole, unless a positive guide is used to secure accurate alignment.

(b) Into a material that can be easily penetrated, unless the material is backed by a substance that will prevent the fastener from passing completely through and creating a flying missile hazard on the other side.

(c) Into a very hard or brittle material, such as cast iron, glazed tile, surface hardened steel, glass block, live rock, face brick, or hollow tile, unless designed for such use. Before fastening any questionable material, the operator shall determine its suitability by using a fastening as a center punch. If the fastener point does not easily penetrate, is not blunted, and does not fracture the material, initial test fastenings shall then be made pursuant to the tool manufacturer’s recommendations.

(d) Directly into material, such as brick or concrete, closer than 3 inches from the unsupported edge or corner, or into a steel surface closer than 1/2 inch from the unsupported edge or corner, unless a special guard, fixture, or jig is used. As an exception, a low velocity powder-actuated tool may drive no closer than 2 inches from the edge in concrete or 1/4 inch in steel. When fastening other material such as a 2 inch by 4 inch wood section to a concrete surface, a fastener of no greater than 7/32 inch shank diameter may be driven not closer than 2 inches from the unsupported edge or corner of the work surface.

(7) A fastener shall not be driven into a spalled area caused by an unsatisfactory fastening.

(8) A powder-actuated tool shall be used with the correct guard, shield, or attachment recommended by the manufacturer.

History: 1979 AC; 1982 AACS; 2013 AACS; 2016 MR 19, Eff. Oct. 13, 2016.

R 408.41944 Powder-actuated tool testing and servicing.

Rule 1944. (1) A powder-actuated tool shall be tested each day before loading to see that safety devices are in proper working order.

(2) The method of testing shall be pursuant to the manufacturer's recommended procedure.

(3) A powder-actuated tool owner shall have the tool serviced and inspected at regular intervals by competent service personnel and shall not permit the tool to be altered or repaired, except by competent repair people.

History: 1979 AC; 1997 AACS.

R 408.41945. Powder-actuated tools; design and construction.

Rule 1945. A powder-actuated tool shall be designed and constructed as prescribed in section 6 of ANSI standard A10.3 "Powder-Actuated Fastening Systems," 1985 edition, as adopted in R 408.41902.

History: 1979 AC; 1997 AACS; 2013 AACS; 2016 MR 19, Eff. Oct. 13, 2016.

R 408.41949. Powder-actuated tool loads and studs.

Rule 1949. (1) Power loads shall be coded and used as prescribed in section 7 and table 1 of ANSI standard A10.3 "Powder-Actuated Fastening Systems," 1985 edition, as adopted in R 408.41902.

(2) Studs or other fasteners used in powder-actuated tools shall be only those specifically manufactured for use in powder-actuated tools.

History: 1979 AC; 1997 AACS; 2013 AACS; 2016 MR 19, Eff. Oct. 13, 2016.

R 408.41950 Powder-actuated tool defects and misfires.

Rule 1950. In case of a misfire, the operator shall hold the powder-actuated tool in the operating position for not less than 30 seconds. The operator shall then try to operate the tool a second time. The operator shall wait another 30 seconds, holding the tool in the operating position, then the operator shall proceed to remove the explosive load in strict accordance with the manufacturer's instructions. Misfired cartridges should be placed carefully in a metal container filled with water and returned to the supervisor for disposal.

History: 1979 AC.

R 408.41951 Woodworking machinery generally.

Rule 1951. (1) A woodworking machine shall have a disconnect switch that can be locked in the off position. This rule does not apply to hand-held tools. An employer shall establish and maintain a lockout procedure. A machine connected to an electrical source by a plug-in cord shall be considered in compliance if the plug is disconnected and tagged.

(2) The vibration of a machine shall not create a hazard to the operator.

(3) An arbor and mandrel shall have a firm and secure bearing.

(4) The frames and all exposed metal parts of electric woodworking machinery shall be grounded. A portable motor driving and electric tool shall be grounded unless it has approved double insulation.

(5) A woodworking machine shall not automatically restart upon restoration of power after a power failure. A machine wired to a 110-volt line before April 11, 1979, is excepted from this rule.

(6) Operating controls shall be located within reach of the operator while the operator is at the regular work station, making it unnecessary to reach over the cutters. The controls shall be installed so as to eliminate the danger of accidental activation. This subrule does not apply to a constant-pressure control used only for setup purposes.

(7) All woodworking machines shall be provided with point of operation guards.

History: 1979 AC; 1989 AACS; 2016 MR 19, Eff. Oct. 13, 2016.

R 408.41952. Woodworking tools and machinery.

Rule 1952. All woodworking tools and machinery shall meet all other applicable requirements of ANSI standard 01.1 "Safety Code for Woodworking Machinery," 1961 edition, as adopted in R 408.41902.

History: 1979 AC; 2013 AACS; 2016 MR 19, Eff. Oct. 13, 2016.

R 408.41953. Circular table saw guards.

Rule 1953. (1) A circular table saw shall have a hood type guard covering the blade at all times when not in use. When in use, the hood type guard shall enclose that part of the blade above the table and that part of the blade above the material by adjusting automatically to the thickness of the material being cut, or it may be a fixed or manually adjusted hood-type guard if the hood remains in contact with the material.

(2) A hood-type guard shall be made of 14-gauge metal or thicker. Plastic may be used if it can resist blows and strains incidental to reasonable operation, adjusting, and handling, and is designed to protect the operator from flying splinters and broken saw teeth. The guard shall be made of material soft enough so that it will be unlikely to cause tooth breakage.

(3) The hood shall be mounted so that its operation is positive, reliable, and in true alignment with the saw. The mounting shall be of sufficient strength to resist any reasonable side thrust or other force tending to throw it out of line.

History: 1979 AC; 2013 AACCS.

R 408.41954. Radial arm saws; guards, spreaders, and stops.

Rule 1954. (1) The upper hood of a radial arm saw shall completely enclose the upper portion of the blade down to a point that includes the end of the saw arbor. The upper hood shall be constructed in a manner and of not less than 14-gauge sheet metal or equivalent material that protects the operator from flying splinters and broken saw teeth and deflects sawdust away from the operator. The sides of the lower exposed portion of the blade shall be guarded to the full diameter of the blade by a device that automatically adjusts itself to the thickness of the stock and remains in contact with the stock being cut to give the maximum protection possible for the operation being performed.

(2) Non-kickback fingers or dogs shall be located on both sides of each radial arm saw blade used for ripping to oppose the thrust or tendency of the saw to pick up the material or to throw it back toward the operator. Non-kickback fingers or dogs shall be designed to provide adequate holding power for all thicknesses of material being cut.

(3) An adjustable stop shall be provided to prevent the forward travel of the blade beyond the position necessary to complete the cut in repetitive operations. A limit chain or other equally effective device shall be provided to prevent the saw blade from sliding beyond the edge of table or the table at that place shall be extended to eliminate overrun.

(4) The cutting head of a radial arm saw shall return gently, without rebound, to the starting position when released by either of the following means:

(a) Sloping the unit.

(b) A counterweight system. This system shall not use fiber and synthetic rope or springs.

History: 1979 AC; 2013 AACCS.

R 408.41955 Band saws.

Rule 1955. (1) All portions of the band saw blade shall be enclosed or guarded, except for the working portion of the blade between the bottom of the guide and the table.

(2) A band saw wheel shall be fully encased. The outside periphery of the enclosure shall be solid. The front and back of the band wheels shall be enclosed by solid material, wire mesh, or perforated metal. Mesh or perforated metal shall be not less than .0037 inch (United States gauge no. 20) and the openings shall be not more than 3/8 of an inch. Solid material used for this purpose shall be of an equivalent strength and firmness. The upper wheel guard shall be made to conform to the travel of the saw on the wheel. The top member of the guard should have not less than a 2-inch clearance outside the saw and be lined with smooth material.

(3) A guard for the portion of the blade between the sliding guide and the upper saw wheel guard shall protect the saw blade at the front and outer side. The guard shall be self-adjusting to raise and lower with the guide. The sliding blade guide shall be kept to within 1/4 inch of the workpiece.

(4) A band saw shall not be stopped by thrusting a piece of wood against the cutting edge of the teeth when the power is off.

(5) A horizontal band saw shall have all portions of the saw blade enclosed, except for the working portion of the blade.

History: 1979 AC; 1989 AACS.

R 408.41956 Rescinded.

History: 1979 AC; 2013 AACS.

R 408.41957. Stationary machine tools generally.

Rule 1957. (1) Machine tools, such as band saws, drill presses, and pipe-cutting and pipe-threading machines, which are set up on a construction project in a temporary stationary position shall have a stop device which is within reach of the operator's designated position and shall have power on/off switch. The switch shall be located and guarded so as to prevent unintentional activation by contact with objects or part of the body.

(2) A foot control shall be provided with a cover or guard that is capable of preventing accidental activation.

History: 1979 AC; 1989 AACS; 2013 AACS.

R 408.41959. Fuel-powered tools.

Rule 1959. (1) A fuel-powered tool shall be stopped before being refueled, serviced, or maintained.

(2) When using a fuel-fired powered tool in an enclosed area, the toxic fumes shall be exhausted as prescribed by Occupational Health Standard Part 621 "Health Hazard Control for Specific Equipment and Operations for Construction," as referenced in R 408.41902.

(3) A fuel-fired portable tool shall be moved a minimum of 10 feet from the place where it was refueled before starting.

(4) A chain saw's chain shall be stopped if it is not being used for sawing. A chain saw shall be carried by the top handle with the guide bar to the rear.

(5) The use of a chain saw to open a hole in a solid object, such as a floor, wall, or panel, is prohibited.

(6) A chain saw's chain shall be guarded adjacent to the handle area. Sawdust from a chain saw shall be directed away from the operator.

History: 1979 AC; 1989 AACS; 2013 AACS; 2016 MR 19, Eff. Oct. 13, 2016.

R 408.41960 Abrasive wheels generally.

Rule 1960. (1) Except for the following operations or tools, an abrasive wheel shall be provided with a guard that cover's the spindle end, nut, and flange projections as well as the periphery:

- (a) Internal grinding while within the work being ground.
- (b) Mounted wheels that are not more than 2 inches in diameter.
- (c) A cup wheel operated at less than 500 revolutions per minute.
- (d) A tuck-point grinder wheel. Such wheel shall be guarded as shown in figure 1.
- (e) Masonry or concrete saws. Such saws may have the spindle end, nut, and flange guarded as shown in figure 2 or 3.

(2) An abrasive wheel shall not be run at a speed that is greater than the rated speed on the wheel.

(3) A cracked or broken abrasive wheel shall not be used.

(4) Eye protection shall be provided to, and used by, each employee operating an abrasive wheel. Eye protection shall comply with the provisions of Construction Safety Standard Part 6 "Personal Protective Equipment," as referenced in R 408.41902.

(5) Figures (1), (2), and (3) read as follows:

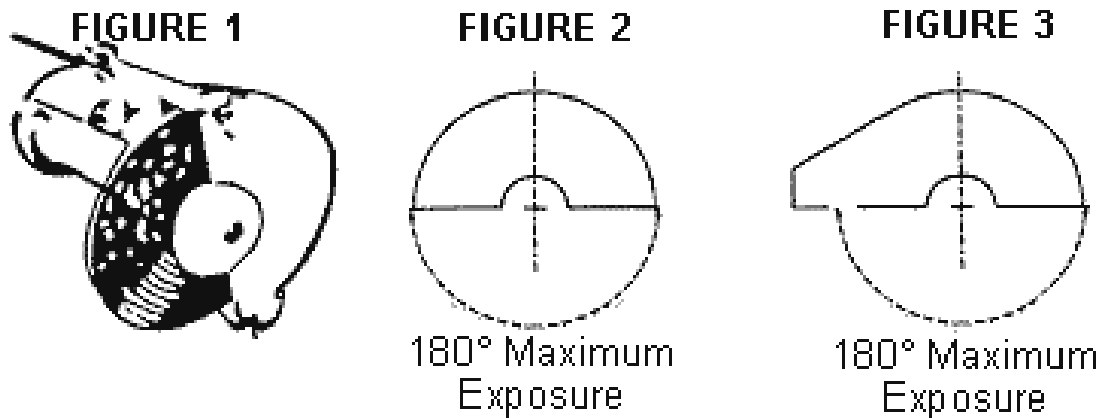

History: 1979 AC; 1989 AACS; 2016 MR 19, Eff. Oct. 13, 2016.

R 408.41961 Offhand grinders; safety devices.

Rule 1961. (1) Offhand grinders shall be equipped with either a work rest or a device that shall prevent the workpiece from jamming between the abrasive wheel and the wheel guard.

(2) A work rest shall be adjusted and maintained to within 1/8 of an inch (0.3175 cm) of the abrasive wheel.

(3) A work rest shall be designed and constructed of metal that is capable of supporting the workpiece. A work rest shall be of rigid construction and designed to be adjustable to compensate for wheel wear.

History: 1979 AC; 1989 AACS; 1995 AACS.

R 408.41962 Hand-held grinders; safety devices.

Rule 1962. (1) A guard on a right angle head or vertical portable grinder shall have the guard located so as to be between the operator and the abrasive wheel during use.

(2) A cup wheel on a portable grinder shall be protected by a band-type or revolving cup guard.

History: 1979 AC; 1989 AACS.

R 408.41964. Hydraulic power tools.

Rule 1964. (1) A hydraulically powered tool shall use approved fire-resistant fluids which do not change the performance characteristics during temperature extremes.

(2) The rated capacity of hydraulic hose, valves, pipe, filters, and other fittings shall not be exceeded.

History: 1979 AC; 1989 AACS; 2013 AACS.

R 408.41966 Jacks generally.

Rule 1966. (1) The rated capacity shall be legibly marked on a jack, and the capacity shall not be exceeded. A jack shall have a positive stop to prevent overtravel.

(2) A hydraulic jack used for lift slab construction shall have a device that causes the jack to support the load in any position if the jack malfunctions.

(3) A lift slab jack system that is automatically controlled shall have a device which stops the operation when a 1/2 inch leveling tolerance is exceeded.

(4) A jack shall be provided a firm foundation. A wood block shall be placed between the load and the metal cap of a jack to prevent slippage.

(5) After a load has been raised, it shall be immediately cribbed, blocked, or otherwise secured.

(6) Hydraulic jacks exposed to freezing temperatures shall be supplied with an adequate antifreeze liquid.

(7) All jacks shall be properly lubricated at regular intervals.

(8) Each jack shall be thoroughly inspected. The frequency of inspections shall be as follows:

(a) For constant or intermittent use at 1 locality, once every 6 months.

(b) For jacks sent out of the shop for special work, when sent out and when returned.

(c) For a jack subjected to abnormal load or shock, immediately before and immediately after being subjected to the load or shock.

(9) Repair or replacement parts shall be examined for possible defects.

(10) Jacks that are out of order shall be tagged accordingly and shall not be used until repairs are made.

History: 1979 AC; 1995 AACS.

R 408.41967 Chain falls and hoist and pullers; capacity.

Rule 1967. (1) A chain fall or hoist and puller shall be used at not more than its rated capacity.

(2) The capacity of a chain fall or hoist and puller shall be permanently labeled or marked on it.

(3) An accessory, such as a chain or cable, used to secure or support a chain fall or hoist and puller shall have a capacity of not less than the chain fall or hoist and puller.

(4) An object subject to a lift or pull by a chain fall shall have the capacity to absorb the lift or pull without creating a hazard to an employee in the area.

History: 1979 AC.

R 408.41968 Chain falls and hoist and pullers; use.

Rule 1968. (1) A chain fall or hoist and puller shall be secured to an anchorage and the load attached to the chain fall or hoist and puller in a manner which prevents inadvertent disengagement.

(2) When a chain fall or hoist and puller is under tension of a load, a positive action shall be required to release the tension.

(3) A hoist and puller lever handle shall not be operated with an extension handle, except as furnished by the manufacturer.

(4) A chain fall or hoist and puller shall be visually inspected for observable defects before each job use by the employee using the tool.

History: 1979 AC.

R 408.41969 Hot sticks.

Rule 1969. (1) A hot stick and any tool attached to it shall be clean and inspected for damage before use.

(2) A hot stick that has been damaged shall not be used until replaced or repaired by a knowledgeable employee or an outside service and tested to meet the requirements of subrule (3) of this rule.

(3) A hot stick shall not be used unless it has been certified and labeled by the manufacturer to meet the following standards:

(a) Fiberglass, 100,000 volts per foot of length for 5 minutes, or any equivalent test.

(b) Wood, 75,000 volts per foot of length for 3 minutes, or any equivalent test.

(4) A hot stick shall be stored in a manner to protect it from damage. A hot stick made of wood shall be protected from moisture.

(5) A hot stick shall not be used in excess of the rated capacity certified by the manufacturer.

(6) The minimum working distance and minimum clear hot stick distances prescribed in table 1, when using live-line tools, shall not be violated.

(7) The minimum working distance for live-line bare-hand technique prescribed in table 2 shall not be violated.

TABLE 1	
ALTERNATING CURRENT MINIMUM DISTANCES	
Voltage Range (phase-to-phase) Kilovolts	Minimum Working and Clear Hot Stick Distance
2.1 to 15	2 ft. 0 in.
15.1 to 35	2 ft. 4 in.
35.1 to 46	2 ft. 6 in.
46.1 to 72.5	3 ft. 0 in.
72.6 to 121	3 ft. 4 in.
138 to 145	3 ft. 6 in.
161 to 169	3 ft. 8 in.
230 to 242	5 ft. 0 in.
345 to 362	¹ 7 ft. 0 in.
500 to 552	¹ 11 ft. 0 in.
700 to 765	¹ 15 ft. 0 in.
¹ NOTE: For 345-362 kv., 500-552 kv., and 700-765 kv., the minimum clearance distance and the minimum clear hot stick distance may be reduced provided that such distances are not made less than the shortest distance between the energized part and a grounded surface.	

TABLE 2		
MINIMUM CLEARANCE DISTANCES FOR LIVE-LINE BARE-HAND WORK (ALTERNATING CURRENT)		
Distance in feet and inches for maximum voltage		
Voltage Range (phase-to-phase) Kilovolts	Phase to Ground	Phase to Phase
2.1 to 15	2 ft. 0 in.	2 ft. 0 in.
15.1 to 35	2 ft. 4 in.	2 ft. 4 in.
35.1 to 46	2 ft. 6 in.	2 ft. 6 in.
46.1 to 72.5	3 ft. 0 in.	3 ft. 0 in.
72.6 to 121	3 ft. 4 in.	4 ft. 6 in.
138 to 145	3 ft. 6 in.	5 ft. 0 in.
161 to 169	3 ft. 8 in.	5 ft. 6 in.
230 to 242	5 ft. 0 in.	8 ft. 4 in.
345 to 362	¹ 7 ft. 0 in.	¹ 13 ft. 4 in.
500 to 552	¹ 11 ft. 0 in.	¹ 20 ft. 0 in.
700 to 765	¹ 15 ft. 0 in.	¹ 31 ft. 0 in.
¹ NOTE: For 345-362 kv., 500-552 kv., and 700-765 kv., the minimum clearance distance may be reduced provided the distances are not made less than the shortest distance between the energized part and a grounded surface.		

History: 1979 AC; 2016 MR 19, Eff. Oct. 13, 2016.

R 408.41970 Rescinded.

History: 1989 AACS; 2013 AACS.

R 408.41971 Rescinded.

History: 1989 AACS; 2013 AACS.

R 408.41972 Powered benders.

Rule 1972. A powered bender shall have 1 of the following:

(a) A barrier or enclosure guard designed to protect the operator from the clamping point of operation.

(b) Either a single-stroke, hand-controlled actuation device which allows 1 hand to hold the workpiece and which is remote from the point of operation or a single-stroke, foot-controlled device which allows both hands to hold the workpiece and which is remote from the point of operation.

(c) A 2-hand, single-stroke control device.

History: 1989 AACCS.

R 408.41973 Alligator shears.

Rule 1973. An alligator shear shall have the jaws enclosed with a guard which adjusts to the size and shape of the material.

History: 1989 AACCS.

R 408.41974 Rescinded.

History: 1989 AACCS; 2013 AACCS.

R 408.41975 Rescinded.

History: 1989 AACCS; 2013 AACCS.

R 408.41976 Controls.

Rule 1976. (1) When a presence-sensing device is used as a safety device, the control shall incorporate a fail-safe feature.

(2) Machine start controls shall be designed and installed or guarded to prevent unintentional activation by contact with objects or a part of the body.

(3) A machine shall be provided with a stop device that is within the reach of the operator's designated position.

(4) A foot control shall be provided with a cover or guard to prevent accidental activation.

History: 1989 AACCS.

R 408.41977. Metalworking machinery or equipment; maintenance and lubrication.

Rule 1977. Any of the following methods shall be used to lubricate metalworking machinery or equipment:

(a) Manual lubrication when the machine can be shut off and locked out.

(b) The use of an automatic pressure or gravity feed system.

(c) The use of an extension pipe leading to an area outside guards or away from any hazard.

(d) The use of a means which would provide equal or greater protection to the employee than the methods specified in subdivisions (a), (b), or (c) of this subrule.

History: 1989 AACCS; 2013 AACCS.

R 408.41978 Hydraulic and pneumatic systems.

Rule 1978. (1) A hydraulic or pneumatic system shall be designed and constructed to have a safety factor of not less than 4.

(2) Hydraulic or pneumatic flexible lines shall be protected from chafing.

(3) To provide for the safety of employees working on or about equipment, when hydraulic, air, or steam lines are bled, equipment supported by these systems shall be physically blocked or otherwise secured by means other than components in the circuit.

History: 1989 AACCS.

R 408.41979 Rescinded.

History: 1989 AACCS; 2013 AACCS.

R 408.41980. Air receivers.

Rule 1980. (1) All new air receivers installed after July 28, 1995, shall be constructed in accordance with the American Society Of Mechanical Engineers (ASME) “Boiler And Pressure Vessel Code,” Section VIII, “Unfired Pressure Vessels,” 1980 edition which is adopted by reference in R 408.41902.

(2) All safety valves used shall be constructed, installed, and maintained in accordance with the ASME “Boiler and Pressure Vessel Code,’ Section VIII, “Unfired Pressure Vessels,” 1980 edition, as adopted in R 408.41902.

(3) Air receivers shall be installed so that all drains, handholes, and manholes are easily accessible. An air receiver shall not be buried underground or located in an inaccessible place.

(4) A drain pipe and valve shall be installed at the lowest point of every air receiver to provide for the removal of accumulated oil and water. Adequate automatic traps may be installed in addition to drain valves. The drain valve on the air receiver shall be opened and the receiver completely drained frequently to prevent the accumulation of excessive amounts of liquid in the receiver.

(5) Every air receiver shall be equipped with an indicating pressure gauge that is located so that it is readily visible and equipped with 1 or more spring-loaded safety valves. The total relieving capacity of the safety valves shall be adequate to prevent pressure in the receiver from exceeding the maximum allowable working pressure of the receiver by more than 10%.

(6) A valve shall not be placed between the air receiver and its safety valve or valves.

(7) Safety appliances, such as safety valves, indicating devices, and controlling devices, shall be constructed, located, and installed so that they cannot be readily rendered inoperative by any means, including the elements.

(8) All safety valves shall be tested frequently at regular intervals to determine whether they are in good operating condition.

History: 1995 AACS; 2013 AACS; 2016 MR 19, Eff. Oct. 13, 2016.